

Meeting Specifics		
<b>Purpose</b>	<b>Frequency</b>	
Regularly Scheduled	Bi-weekly	
<b>Date</b>	<b>Time</b>	<b>Location</b>
May 4, 2026	3:00-5:00 p.m.	Ralph G. Anderson Room 207
Faculty Senate		
<input checked="" type="checkbox"/> <b>Chair:</b> Crawford, Christopher	<input checked="" type="checkbox"/> <b>Design:</b> Fugate, Jeff	<input type="checkbox"/> <b>Honors:</b> Martin, Joe
<input checked="" type="checkbox"/> <b>Provost Liaison:</b> Harper, Christine	<input checked="" type="checkbox"/> <b>Design:</b> O'Bryan, Mark	<input checked="" type="checkbox"/> <b>Honors:</b> Roberts, Sherelle
<input checked="" type="checkbox"/> <b>Trustee:</b> Petrone, Karen	<input checked="" type="checkbox"/> <b>Education:</b> Bennett, Stephanie	<input checked="" type="checkbox"/> <b>Libraries:</b> Weig, Eric
<input checked="" type="checkbox"/> <b>Trustee:</b> Swanson, Hollie	<input checked="" type="checkbox"/> <b>Education:</b> Hammer, Joe	<input checked="" type="checkbox"/> <b>Libraries:</b> McDonnell, Andrew
<input checked="" type="checkbox"/> <b>Agriculture, Food &amp; Environment:</b> Rentfrow, Gregg	<input checked="" type="checkbox"/> <b>Engineering:</b> Anderson, Kimberly	<input checked="" type="checkbox"/> <b>Medicine:</b> Akpunonu, Peter
<input checked="" type="checkbox"/> <b>Agriculture, Food &amp; Environment:</b> Teets, Nicholas	<input checked="" type="checkbox"/> <b>Engineering:</b> Poovathingal, Savio	<input checked="" type="checkbox"/> <b>Medicine:</b> Thibault, Olivier
<input checked="" type="checkbox"/> <b>Arts &amp; Sciences:</b> Voss, Steve	<input checked="" type="checkbox"/> <b>Fine Arts:</b> Alley, Becky	<input type="checkbox"/> <b>Nursing:</b> Biddle, Martha
<input checked="" type="checkbox"/> <b>Arts &amp; Sciences:</b> Stein, Melissa	<input checked="" type="checkbox"/> <b>Fine Arts:</b> Kerns, Bradley	<input checked="" type="checkbox"/> <b>Nursing:</b> Falls, Candace
<input checked="" type="checkbox"/> <b>Business &amp; Economics:</b> Hapke, Holly	<input checked="" type="checkbox"/> <b>Graduate School:</b> Butler, John "J.S."	<input checked="" type="checkbox"/> <b>Pharmacy:</b> Freeman, Trish
<input checked="" type="checkbox"/> <b>Business &amp; Economics:</b> Vincent, Leslie	<input checked="" type="checkbox"/> <b>Graduate School:</b> Montgomery, Kathleen	<input checked="" type="checkbox"/> <b>Pharmacy:</b> Bauer, Bjoern
<input checked="" type="checkbox"/> <b>Communication &amp; Information:</b> Tai, Zixue	<input checked="" type="checkbox"/> <b>Health Sciences:</b> Hoch, Johanna	<input checked="" type="checkbox"/> <b>Public Health:</b> Haynes, Erin
<input checked="" type="checkbox"/> <b>Communication &amp; Information:</b> Vallade, Jessalyn	<input checked="" type="checkbox"/> <b>Health Sciences:</b> Metzler-Wilson, Kristen	<input checked="" type="checkbox"/> <b>Public Health:</b> Ingram, Richard
<input checked="" type="checkbox"/> <b>Dentistry:</b> Dominguez Fernandez, Enif	<input checked="" type="checkbox"/> <b>Law:</b> Henke, Melissa	<input checked="" type="checkbox"/> <b>Social Work:</b> Jones, Aubrey
<input checked="" type="checkbox"/> <b>Dentistry:</b> Wiemann, Alfred	<input checked="" type="checkbox"/> <b>Law:</b> Murray, Michael	<input checked="" type="checkbox"/> <b>Social Work:</b> Ratliff, Stephanie
Standing Guests and Visitors		
<input checked="" type="checkbox"/> DiPaola, Bob	<input checked="" type="checkbox"/> Harmon, Camille	<input type="checkbox"/> Thomas, Rebecca
<input checked="" type="checkbox"/> Jasinski, Jana	<input checked="" type="checkbox"/> Frisby, Brandi	<input type="checkbox"/> Benton, Julie
<input checked="" type="checkbox"/> <b>Visitor:</b> Morgan, Shauna	<input checked="" type="checkbox"/> <b>Visitor:</b> Thyne, Clayton	<input checked="" type="checkbox"/> <b>Visitor:</b> Agyemang, Kwame
<input checked="" type="checkbox"/> <b>Visitor:</b> Jones, Davy	<input checked="" type="checkbox"/> <b>Visitor:</b> Franco-Watkins, Ana	<input checked="" type="checkbox"/> <b>Visitor:</b> Sheather, Simon
<input checked="" type="checkbox"/> <b>Visitor:</b> Martin, Craig	<input checked="" type="checkbox"/> <b>Visitor:</b> Duff, James	<input checked="" type="checkbox"/> <b>Visitor:</b> Way, Doug
<input checked="" type="checkbox"/> <b>Visitor:</b> Lephart, Scott	<input checked="" type="checkbox"/> <b>Visitor:</b> Griffith, Charles	<input checked="" type="checkbox"/> <b>Visitor:</b> Bryan, Laura
<input checked="" type="checkbox"/> <b>Visitor:</b> Buchheit, Rudy	<input checked="" type="checkbox"/> <b>Visitor:</b> Bush, Heather	<input checked="" type="checkbox"/> <b>Visitor:</b> Pace, Nick
<input checked="" type="checkbox"/> <b>Visitor:</b> Van Tatenhove, Greg	<input checked="" type="checkbox"/> <b>Visitor:</b> The, Tiana	<input checked="" type="checkbox"/> <b>Visitor:</b> Okeson, Jeff
<input checked="" type="checkbox"/> <b>Visitor:</b> Nathan Vanderford	<input checked="" type="checkbox"/> <b>Visitor:</b> Gribble, Phillip	<input checked="" type="checkbox"/> <b>Visitor:</b> Shanda, Mark
<input checked="" type="checkbox"/> <b>Visitor:</b> Fraga, Jesse	<input checked="" type="checkbox"/> <b>Visitor:</b> Sanger, Matt	<input checked="" type="checkbox"/> <b>Visitor:</b> Crankshaw, Ned
<input checked="" type="checkbox"/> <b>Visitor:</b> Moreland, Gwen	<input type="checkbox"/> <b>Visitor:</b>	<input type="checkbox"/> <b>Visitor:</b>

Agenda Item	Presenter/Facilitator
Roll Call   Approval of the Minutes 5 min	C. Crawford
Opening Remarks   Updates   Announcements 10 min	C. Crawford
New Program/Certificate Proposals 20 min	J. Hammer
Provost Updates and Consultation 45 min	B. DiPaola/ C. Harper
Title Series Ad Hoc Committee Updates 20 min	L. Vincent/ J. Hoch
Shared Governance Committee Updates 5 min	B. Alley

Senate Curriculum Committee Updates 5 min	J. Hammer
Faculty Affairs Committee Updates 5 min	L. Vincent
Faculty Trustee Updates 5 min	H. Swanson/ K. Petrone
Call for Agenda Items	C. Crawford
Next Meeting Fall 2026   3:00-5:00 p.m.   Business and Economics Rm. 191	

**Minutes**

**Agenda Item:** Roll Call | Approval of the Minutes

**Presenter:** C. Crawford

- C. Crawford called the meeting to order at 3:00p.m.
- Faculty Senate went through roll call.
- April 20 meeting minutes were approved.
- April 27 meeting minutes were approved.

**Agenda Item:** Opening Remarks | Updates | Announcements

**Presenter:** C. Crawford

- C. Crawford provided opening remarks to the Faculty Senate.
  - C. Crawford presented his final report on the state of the Faculty Senate from the chair's perspective. C. Crawford stated that many of you were here for my first 'lecture' on signal processing-- I would like to follow up in the same language that feels natural to me. These first few images are something you might see on an oscilloscope. In our early meetings, as we experienced the Gibbs phenomenon: 'ringing' that occurs during a sudden transition, because there is no natural frequency of a step function, L. Vincent presented the four steps to team building: forming, storming, norming, and performing and I showed this image as 'proof' that we would reach a new equilibrium through our collective damping effects. We worked through our storming phase by communicating our frustrations while both the Faculty Senate and Administration exercised restraint. During the formation stage, there was quite a bit of resistance to the establishment of committees, but I am grateful that we approved them in the end, because I feel that most of our work was accomplished in committee. I am grateful to our committee chairs, J. Jensen, M. O'Bryan, and J. Hammer as subsequent chairs of the Senate Curriculum Committee (SCC), B. Alley, chair of the Shared Governance Committee (SGC), and L. Vincent, chair of the Faculty Affairs Committee (FAC) for their help in building momentum in the Faculty Senate. As for the norming stage, we Faculty Senators are a very diverse body. We equally represent each of the 19 colleges, 6 title series, at various stages in our career, experts in diverse fields, and with just as many opinions. I feel we have come in tune with each other while respecting our individual points of view. In music, different matched frequencies can harmonize, and each of our overtones have mixed to form the rich timbre of our Faculty Senate. Within the Senate, I held open office hours to be as inclusive as possible, and I hope that each of you have felt your voice and contributions were valued. In the future, you may consider an executive body to support the Chair. Our voice is an important one in the symphony of shared governance. At the last Board meeting, Trustee Gray declared, "These shared governance standards are often cumbersome and troublesome, like democracy, but they have proven over time to be essential to institutional stability, credibility, and progress. And once ceded, once abdicated and given away, it's a slippery slope and tough to recover." So, congratulations, we've graduated to the performing stage! The SCC has led us to coherence in Senate curricular review. The SGC has led the Faculty Senate statements on ARs as they came out and established a new Faculty Senate newsletter. The FAC led us through the colossal exercise of UK-FRAME in the fall. L. Vincent and J. Hoch let an ad-hoc committee that will present an interim report on Title Series today. M. Stein led an ad-hoc committee to report on recertification and proposed new areas of UK Core. H. Hapke and others helped plan our Retreat and Summit. Trustees Ballard, Swanson, and Petrone have deliberated with us and represented our perspective to the Board, reporting the outcomes. We thank the

Office of the Provost for giving us three charges over the past year and involving our Senate in important academic issues. We acknowledge our advisory role and feel we can have an impact as such. I've mentioned the special role the Faculty Senate plays with its inverted hierarchy, especially ways in which we can generate cohesion between faculty and administration that are impossible through line management. We've stressed our role in transparency through the feedback loop of dialog between administration and faculty as policies are developed. Fun fact, the image on slide 4 is an amplifier circuit, this operational amplifier (triangle) has a gain of over 10 million, but it is the balance of resistors R1 and R2 that temper its output and create faithful representation of the original signal. That is the role of Shared Governance. Another fun fact is that there is a typo in this figure: feedback on the positive side amplifies small changes, blowing them out of proportion; it is negative feedback that tempers stability and fidelity. There are other impedances besides resistors, which affect our signals differently. Current flowing through a capacitor gets blocked as the plates fill up with positive and negative charge while electrons can't span the gap. From my perspective, while we have cohered as a Faculty Senate and developed open communication among ourselves, our most challenging unsolved problem is the same as "the last mile" problem of our previous generation in getting fiber optic signals from the last exchange to every household. Senators not being able to communicate freely with the 50-1500 faculty in their colleges has truly impeded our connection and our ability to truly represent our constituents in a meaningful way. Our incoming chair, J. Hoch, has come up with exciting new ideas to fix this, and just as we all have blazing 1 GigE in our homes, I have high hopes for a fluid connection between Senators and their faculty. The last impedance is not a gap, but just a coil of wire whose magnetic fields give inertia to electrical current and prevent changes. I view my primary role as coordinating the establishment of momentum in the Senate. I want to thank each of you, our committees and chairs, office hour regulars, and the Office of the Provost for pushing against the laws of nature and establishing a functional Faculty Senate. Just as many voices contribute to the richness of our Senate and shared governance in the University, I am excited for J. Hoch to add her own voice in shaping our Senate and look forward to a wonderful future in her stewardship.

- A motion was made to accept the chair's report.
- The motion to accept the chairs report passed.
- Please see Appendix A for the presentation slides.

**Agenda Item:** New Program/Certificate Proposals

**Presenter:** J. Hammer

- J. Hammer provided updates from the Senate Curriculum Committee (SCC).
  - The Faculty Senate has been asked to review and provide a recommendation on eight proposals.
    - BA – Creative Writing – New
    - BFA – Creative Writing – New
    - MS - Organizational Leadership and Coaching in Sport – New
    - Undergraduate Certificate - One Health – New
    - Graduate Certificate – Sport Social Work – New
    - Graduate Certificate – Universal Design – New
    - Graduate Certificate – Social Work Informed Library Services – New
    - Graduate Certificate- School Technology Leadership- Close
  - J. Hammer asked S. Morgan to provide a brief overview of the proposed BA/BFA Creative Writing.
    - S. Morgan gave an overview of the proposed BA/BFA Creative Writing stating that the degree programs provide students with a multi-disciplinary approach to honing their writing, editing, and critical thinking skills. The degree programs meet a growing demand for students consistently engaged in creative writing and will prepare students for the private sector and continued education in graduate programs. Building on the University's Literary legacy dating back to 1946, the BA/BFA Creative Writing provides students with a flexible pathway to engage with colleges and departments beyond the College of Arts and Sciences to enhance their writing and craft.

- The Faculty Senate discussed the BA/BFA Creative Writing. That discussion included what the difference is between the BA and BFA and what pathways will be available for students to double major.
      - S. Morgan shared that students pursuing the BFA will complete an in-depth thesis and other professional requirements, and that students pursuing the BA will have enough flexibility in their elective requirements to double major or minor in another discipline.
  - J. Hammer asked K. Agyemang to provide a brief overview of the proposed MS Organizational Leadership and Coaching in Sport.
    - K. Agyemang gave an overview of the proposed MS Organizational Leadership and Coaching in Sport. The proposed degree program is currently a specialization in MS Kinesiology and Health Promotion. Creating a stand along degree will build on existing expertise and make the program more marketable to students.
      - The Faculty Senate discussed the MS Organizational Leadership and Coaching in Sport.
    - K. Agyemang shared that Equine Science is housed in the M-G College of Agriculture, Food and Environment, and that they hope to collaborate with other programs within the University.
  - J. Hammer reminded the Faculty Senate to record their official recommendation via Curriculum for the eight proposals by 5:00pm Tuesday, May 5.

**Agenda Item:** Provost Updates and Consultation

**Presenter:** B. DiPaola

- B. DiPaola provided updates from the Office of the Provost. In response to a request from the Faculty Senate chair, B. DiPaola gave an overview of the college dean hiring process.
  - The University adheres to a process that has been constructed to maximize input and hear all voices. The University values the Integrity and consistency of the search process paying attention to what would be best for the college in the moment and ensuring alignment with the University mission of service, research, and education. College dean searches have four stages that include organization, recruitment, interviews, and final announcement. Each stage includes an opportunity for input and debriefing. In creating a Search Advisory Committee (SAC), the University ensures that there is representation from faculty, staff, students and alumni with college faculty making up majority of SAC members. The SAC follows each candidate through the entire search process. The interviews in stage three include screening interviews, off-site interviews and on-campus interviews. The SAC debriefs with the Provost after each interview. The college engages with the candidates in several ways throughout the search process through interviews and feedback.
- B. DiPaola introduced P. Gribble, incoming dean of the College of Health Sciences, and shared that the two new deans are very receptive and open to meeting with the Faculty Senate before they depart for the summer.
  - P. Gribble thanked the Faculty Senate for allowing him to attend the Faculty Senate meeting. The College of Health Sciences has been his home for the last 12 years. He is excited to lead the faculty staff and students into the next season.
- B. DiPaola went over the College of Law search timeline emphasizing that the process is the same for every dean search. There were two areas of concern around the College of Law search. The concerns included whether the candidates were academic enough and if the candidates met the American Bar Associates (ABA) standards. To ensure due diligence, B. DiPaola called over half of the College of Law faculty to better understand if they had the same concerns and consulted with a prior chair of ABA. ABA Standard 203 has three clauses (a) A law school shall have a full-time dean with the authority and support necessary to discharge the responsibilities of the position. (b) Except in extraordinary circumstances, a dean shall also hold appointment as a member of the faculty with tenure. (c) The dean shall be selected by the university or the governing board of the law school, as appropriate, which shall have and follow a procedure for decanal appointment or reappointment that assures meaningful involvement by the faculty or a representative body of the faculty in the selection of a dean. B. DiPaola shared that the incoming dean has the executive leadership skills to mentor and lead the college and that they do not have a goal of tenure. Their priority is the growth of the faculty and scholarship in the college. B. DiPaola emphasized that there is no question that there was meaningful involvement of the faculty from the College of Law in the search process.

Referring to a quote from David Levi, 14<sup>th</sup> dean of Duke College of Law, B. DiPaola noted that other institutions have successfully appointed similarly experienced leaders as deans.

- B. DiPaola introduced Judge Van Tatenhove, incoming dean of the J.D. Rosenberg College of Law.
  - Judge Van Tatenhove thanked the Faculty Senate for allowing him to attend the Faculty Senate meeting. He noted that he has been through three full FBI investigations, two presidential nominations, and two senate confirmations – none of which compared to the rich process of the dean search. He has been approved to start transition work, which has allowed him to begin meeting with college faculty. He shared that he is committed to, and focused on the future of, the College of Law.
- To attest to shared governance in an advisory setting, B. DiPaola noted that he signed over 180 letters of promotion over the weekend. Of those 180 letters, administration and faculty were about 98% in agreement in terms of promotion. That confirms the success of this institution and the faculty growing in their careers. B. DiPaola reminded the Faculty Senate that Commencement is at the end of the week and that they are all welcome to attend the spectacular event.
  - The faculty senate discussed the college dean search updates. The discussion included whether the numbers in reference to how many constitute majority are shareable, why there is a level of confidentiality placed on SAC members that doesn't seem to apply to the Office of the Provost, what constitutes an extraordinary circumstance, and whether the assumption is true that BOT previously approved dean hires.
- B. DiPaola shared that there aren't clear numbers and it isn't a matter of how many votes. They must look at the scope and complexity of the college, which involves multiple factors. B. DiPaola shared that must ensure confidentiality early in the process to protect individuals that want to apply and aren't sure if they are going to move forward and don't want to risk their current position. He is open to discussing and modifying the confidentiality agreement, but the agreement is there to protect the applicants. B. DiPaola clarified that his reference to extraordinary circumstances is defined by ABA standards. B. DiPaola stated that they abide by Governing Regulation I, II, and III in response to the question about whether the Board previously approved college dean hires. There has been a call for a collaborative workgroup of University stakeholders to review the GRs and report back at the next Board meeting. B. DiPaola emphasized that if the GRs were to change, they would abide by those revised GRs as well.
- B. DiPaola stated that he is always willing to listen to input from the Faculty Senate, and that he would be happy to continue this discussion in the fall. B. DiPaola congratulated C. Crawford on the work he has put into creating a functional Faculty Senate.
- C. Crawford reiterated the creation of a system to work together and reestablish a relationship of trust with the Office of the Provost. C. Crawford noted two other items of discussion including an update to the Board at their June meeting on UK FRAME and a discussion on HB 490.
- C. Harper shared that as the Office of the Provost finalizes the UK FRAME model, they are looking for a group of faculty to pilot the process. The pilot group would work through the process and provide feedback that can be summarized and shared with Faculty Senate over email late this summer. C. Harper stated that they are hoping to have 1-2 faculty from each college participate in pilot.
- C. Crawford noted that his concern as chair was the actual formulas being used in UK FRAME. That is being pushed to the college, so that won't be part of what the Faculty Senate would be able to evaluate.
  - The Faculty Senate discussed the update on UK FRAME. That discussion included how faculty would be selected for the pilot, if the Office of the Provost would ensure representation from the Faculty Senate, and what the timeline is from UK FRAME.
- C. Harper shared that if a Senator was on a 12-month appointment and wants to participate in the pilot, that they can send her an email. The Office of the Provost is still working through how they will identify faculty, but they will ensure representation from every college. C. Harper noted that if you are off contract over the summer, you would be volunteering to participate and that there was no funding available to pay the Faculty Senate to participate over the summer. In reference to the timeline, C. Harper stated that they would like to know if any Faculty Senators would like to participate in the pilot by the end of the week. They would fill any gaps after that deadline had passed. The hope is that in the next 2-3 weeks there is a finalized approach that we can move forward with.
  - The Faculty Senate discussed whether they would want a way to respond to UK FRAME in June, and then consensus was that they would want to see a report before deciding whether a response would be needed.

- C. Crawford introduced the topic of HB 490. The University needs to respond to HB 490 by Oct 1, which means that the University’s response would need to be approved by the Board at the September meeting. C. Crawford noted the hard work by those who created a shared document to look at policies from other institutions and noted that The Faculty Senate could move forward with the policy adopted by the AAUP.
  - The Faculty Senate discussed HB 490. That discussion included what the ask was of the Faculty Senate and that there is a need for more deliberation on specifics before making a recommendation.
- C. Crawford stated that policy will have to be developed this summer, and that anything that the Faculty Senate can vote on at this meeting could have a positive impact on the policy developed.
  - B. Alley made a motion for the SGC to start a document that would include definitions and processes that will be available to all senators over the summer, and that a committee be charged in the fall with tightening up that document before it is voted on.
    - C. Crawford made a friendly amendment to include that the document also be shared with administration as they discuss the policy this summer.
  - The Faculty Senate discussed whether the Office of the Provost already had a plan and where the new policy would appear.
  - B. DiPaola stated that the Office of the Provost is receptive to the feedback from the Faculty Senate and that they don’t know yet where that policy will be housed.
  - The motion for the SGC to start a document that would include definitions and processes that will be available to all senators and administrators over the summer, and that a committee be charged in the fall with tightening up that document before it is voted on passed.

**Agenda Item:** Title Series Ad Hoc Committee Updates

**Presenter:** L. Vincent/J. Hoch

- L. Vincent provided an update from the Title Series Ad Hoc Committee.
  - The process of looking at the title series fit into three buckets.
    - Evaluation of the current ARs and Title Series structure.
    - Benchmarking to learn about the structure at peer and aspirant institutions.
    - Faculty feedback survey- data collection on going.
  - L. Vincent and J. Hoch have looked at preliminary results of the survey and completed some qualitative analysis. Their current focus is on operationalizing.
  - J. Hoch thanked senators and the deans for their support in sending out the survey. She indicated that they want to focus effort on administrative feedback as it relates to title series.
    - The Faculty Senate discussed whether the emails that were sent on behalf of faculty outside of the survey were incorporated into their research and if they could define what missing meant in the data table.
  - L. Vincent shared that she kept all emails and that the feedback had been part of the conversation. The definition for missing in the data table is those who left the question about their title series blank.
- Please see Appendix B for presentation slides.

**Agenda Item:** Shared Governance Committee Updates

**Presenter:** B. Alley

- B. Alley provided updated from the Shared Governance Committee (SGC).
  - B. Alley shared that the Faculty Senate newsletter will be coming out this week and reminded Senators to forward the newsletter to their college faculty. B. Alley stated that Senators are welcome to add a message to the faculty in their college when they forward it.

**Agenda Item:** Senate Curriculum Committee Updates

**Presenter:** J. Hammer

- J. Hammer had no updates from the Senate Curriculum Committee.

<b>Agenda Item:</b> Faculty Affairs Committee Updates	<b>Presenter:</b> L. Vincent
<ul style="list-style-type: none"> <li>L. Vincent had no updates from the Faculty Affairs Committee.</li> </ul>	
<b>Agenda Item:</b> Faculty Trustee Updates	<b>Presenter:</b> H. Swanson/K. Petrone
<ul style="list-style-type: none"> <li>H. Swanson and K. Petrone provided updates from the Faculty Trustees. <ul style="list-style-type: none"> <li>H. Swanson shared that a formal update on the status and impact of Integrate Blue will be presented at the June Board meeting.</li> <li>H. Swanson stated that this was her last trustee report and her last Faculty Senate meeting. The incoming faculty trustee, Nathan Vanderford will begin July 1.</li> <li>K. Petrone shared that the June Board meeting will include several topics include UK FRAME, Integrate Blue, and Governing Regulations.</li> </ul> </li> </ul>	
<b>Agenda Item:</b> From the Floor	<b>Presenter:</b> Faculty Senate
<ul style="list-style-type: none"> <li>L. Vincent thanked C. Crawford for his leadership, time, and effort as the first chair of the Faculty Senate.</li> </ul>	
<b>Agenda Item:</b> Call for Agenda Items	<b>Presenter:</b> C. Crawford
<ul style="list-style-type: none"> <li>S. Roberts is interested in hearing and update on the intellectual property AR in the fall.</li> <li>C. Crawford reiterated that the Faculty Senate would like to hear feedback on all of the ARs where they provided feedback.</li> </ul>	
<b>Other Information</b>	
<b>Adjournment</b>	
<ul style="list-style-type: none"> <li>Meeting adjourned at 5:05p.m.</li> </ul>	
<b>Next Meeting</b>	
<ul style="list-style-type: none"> <li>Fall 2026 3:00-5:00p.m., Business and Economics Room 191</li> </ul>	

## Signal Processing – part II

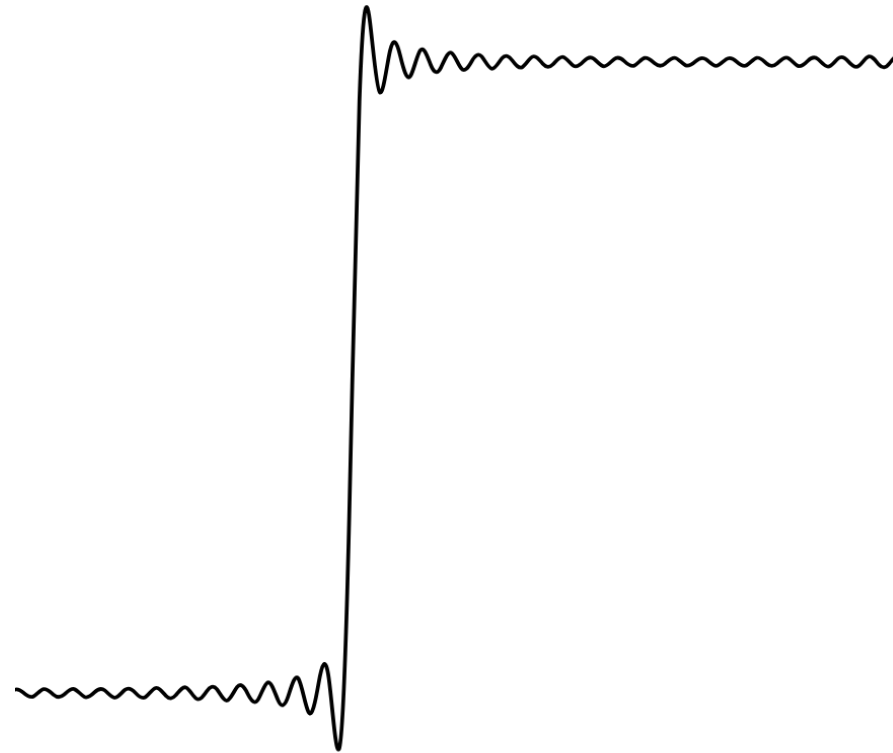

[https://en.wikipedia.org/wiki/Gibbs\\_phenomenon](https://en.wikipedia.org/wiki/Gibbs_phenomenon)

# Harmonics

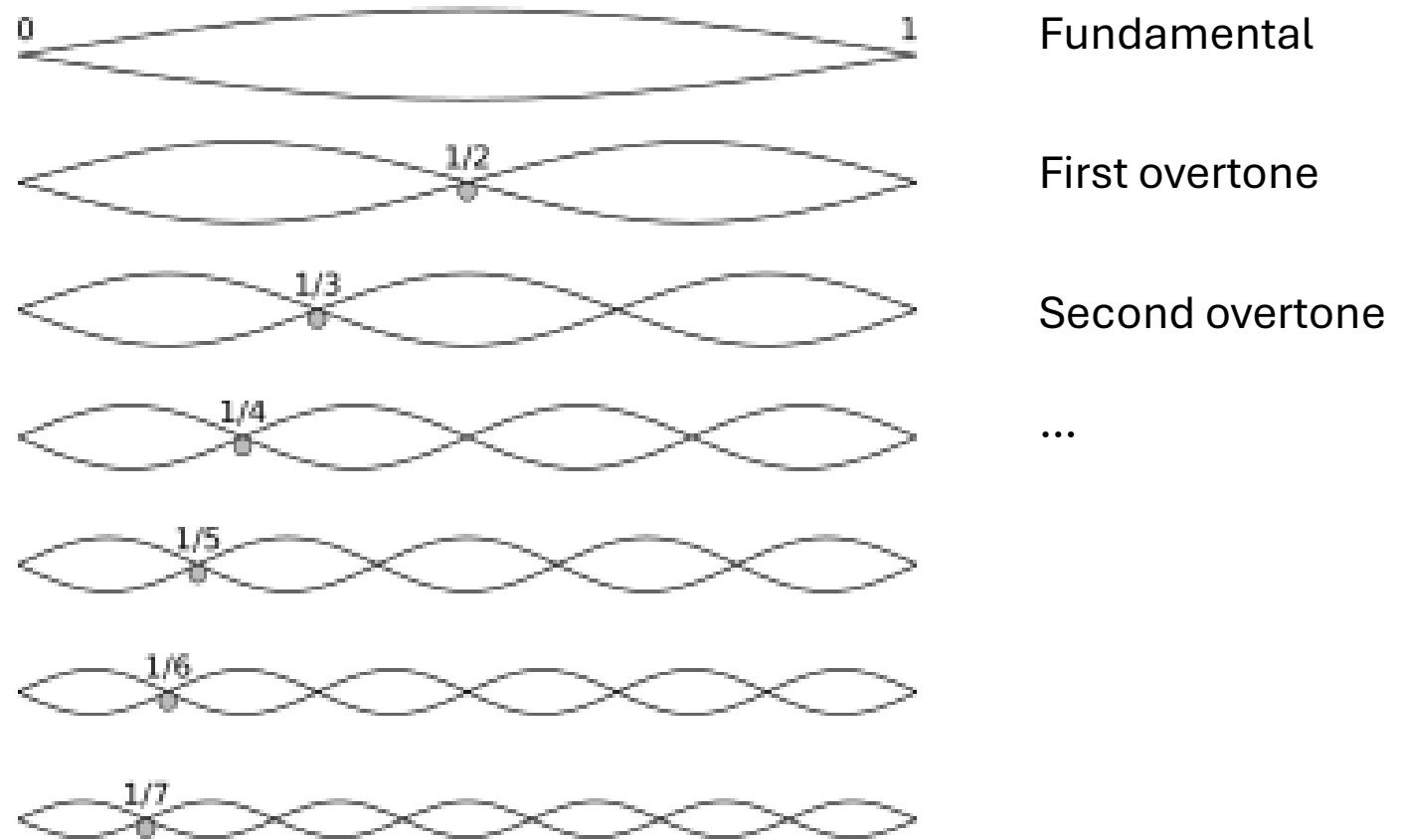

[https://en.wikipedia.org/wiki/Harmonic\\_series\\_%28music%29](https://en.wikipedia.org/wiki/Harmonic_series_%28music%29)

# Timbre

Tuning fork

Clarinet

Trumpet

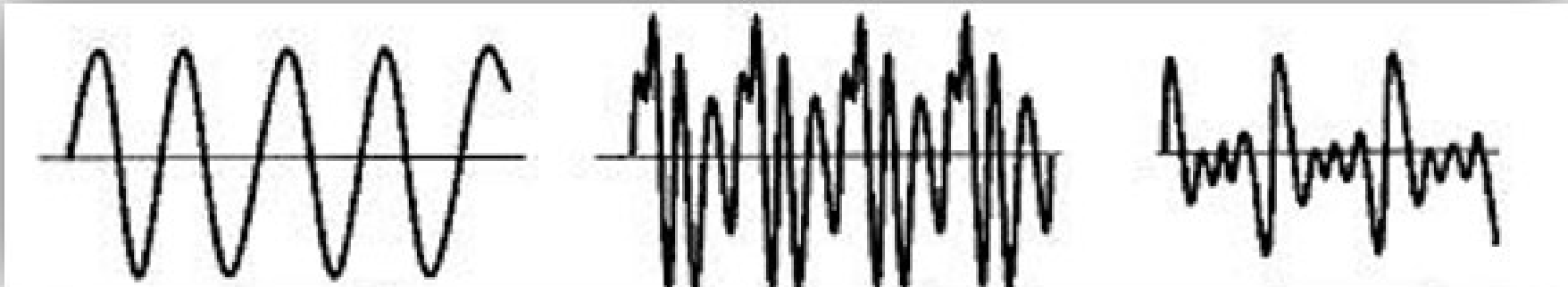

<https://www.simplifyingtheory.com/timbre>

# Feedback

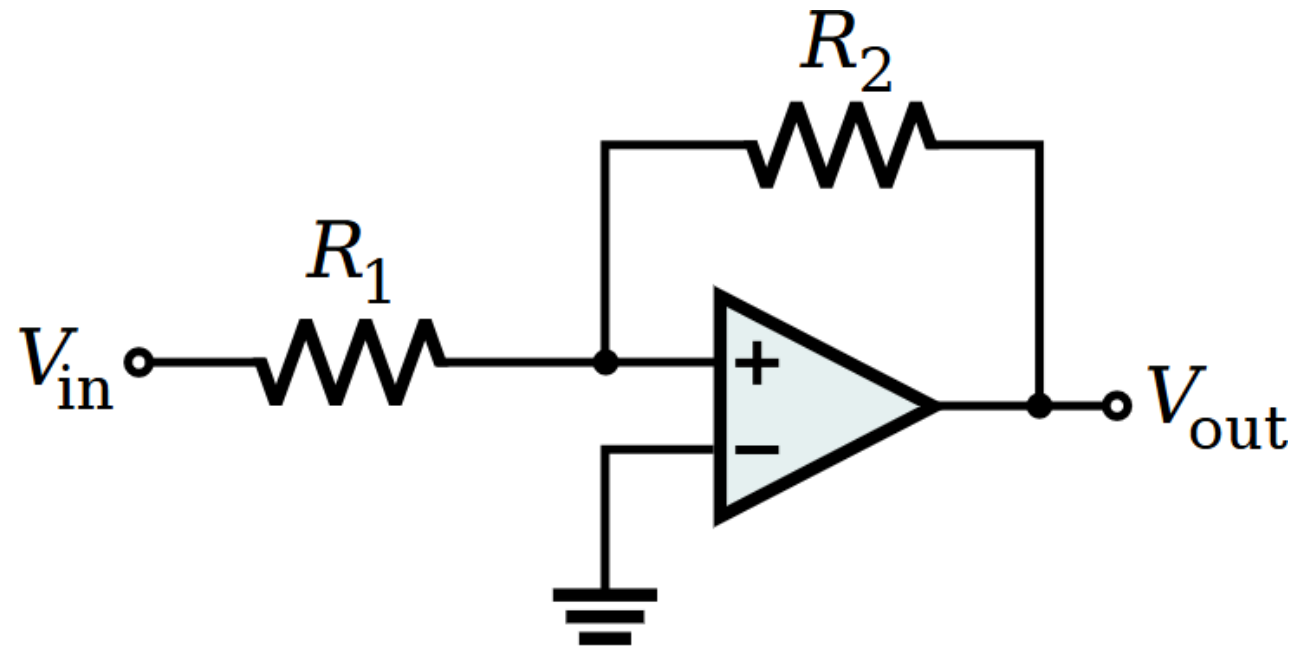

[https://en.wikipedia.org/wiki/Operational\\_amplifier](https://en.wikipedia.org/wiki/Operational_amplifier)

# Capacitance

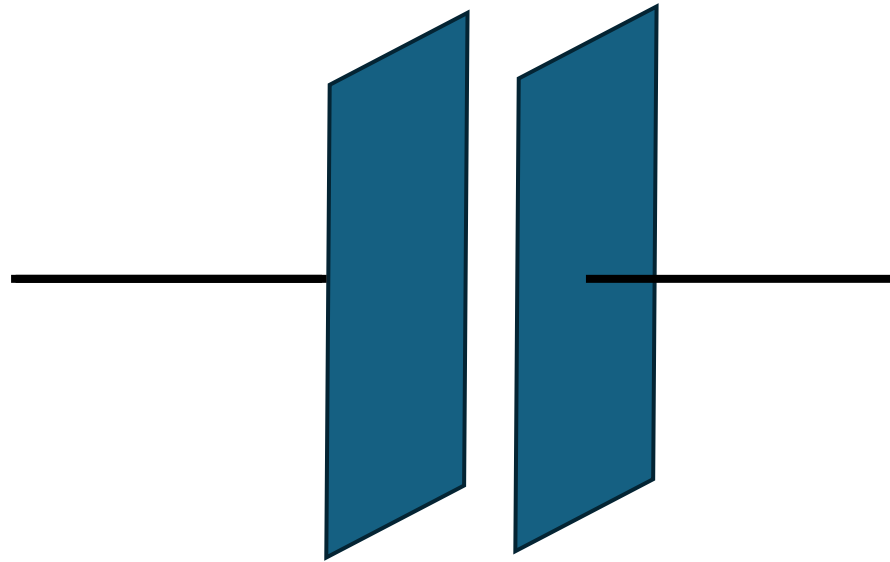

# Inductance

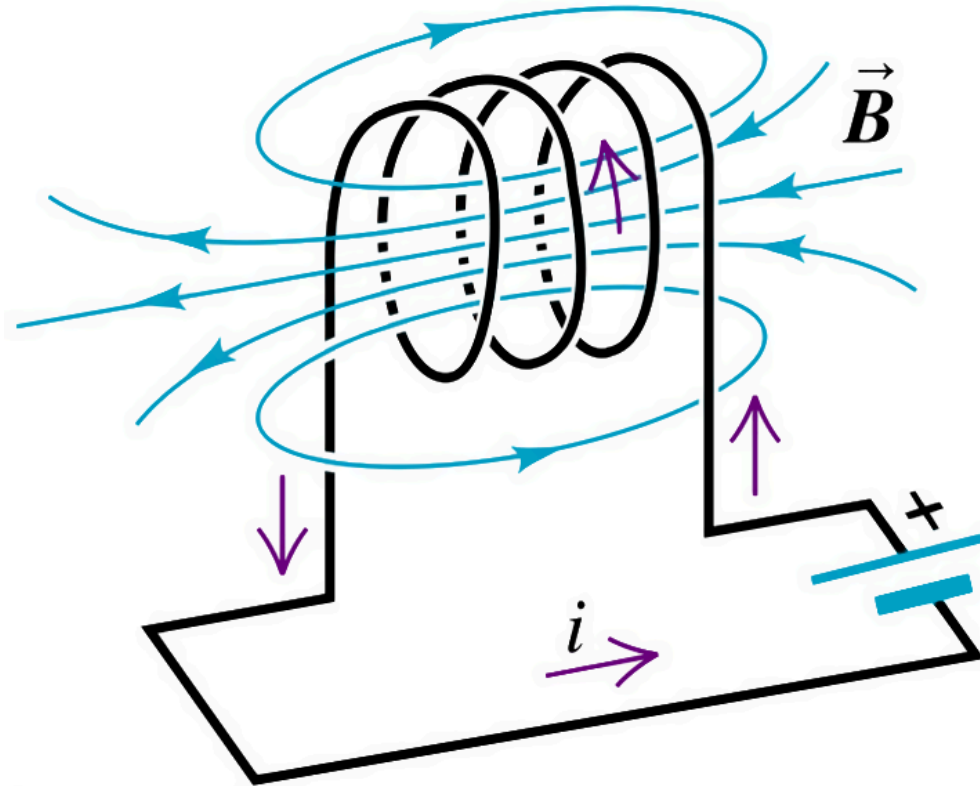

<https://commons.wikimedia.org/wiki/File:Inductor.png>

## Faculty Title Series Structure Review: Interim Update

May 4, 2026

# Process Update

## Evaluation of the current ARs and Title Series structure

- Review of ARs
- Data provided from Provost's Office evaluated and compiled to provide understanding of the number within each title series and associated DOEs

## Benchmarking to learn about the structure at peer and aspirant institutions

## Faculty feedback survey – data collection ongoing

- Deadline extended to Friday, May 8
- Quantitative and qualitative analysis

# Current Response Rate by Title Series\*

	Frequency	Percent	Valid Percent
Regular	269	38.9	37.8
Research	31	4.5	3.9
Lecturer	96	13.9	14.8
Clinical	109	15.8	16.4
Extension	23	3.3	3.4
Librarian	21	3.0	3.3
Special	117	16.9	17.3
Adjunct	8	1.2	0.8
Part-Time	3	0.4	0.4
Post-Retirement	12	1.5	1.7
Visiting	1	0.1	0.1
Voluntary	1	0.1	0.1
Total	691	84.2	100.0
Missing	130	15.8	
Total	821	100.0	

\*As of 5:30 pm – 5/1/2026

# Next Steps



Analyze survey results

Analysis by title series

Content analysis of strengths and weaknesses or current structure



Take current ARs and evaluate against feedback from survey



Collect data to reflect the voice of administration



Conduct additional research as needed to explore findings from the survey results.